

**LAYOUT
MODEL 1720**

Scale	None
--------------	------

© ALL RIGHTS RESERVED
2003 FREEMAN MARINE EQUIPMENT, INC.
SPECIFICATIONS SUBJECT TO CHANGE WITHOUT NOTICE

**LAYOUT
MODEL 1720**

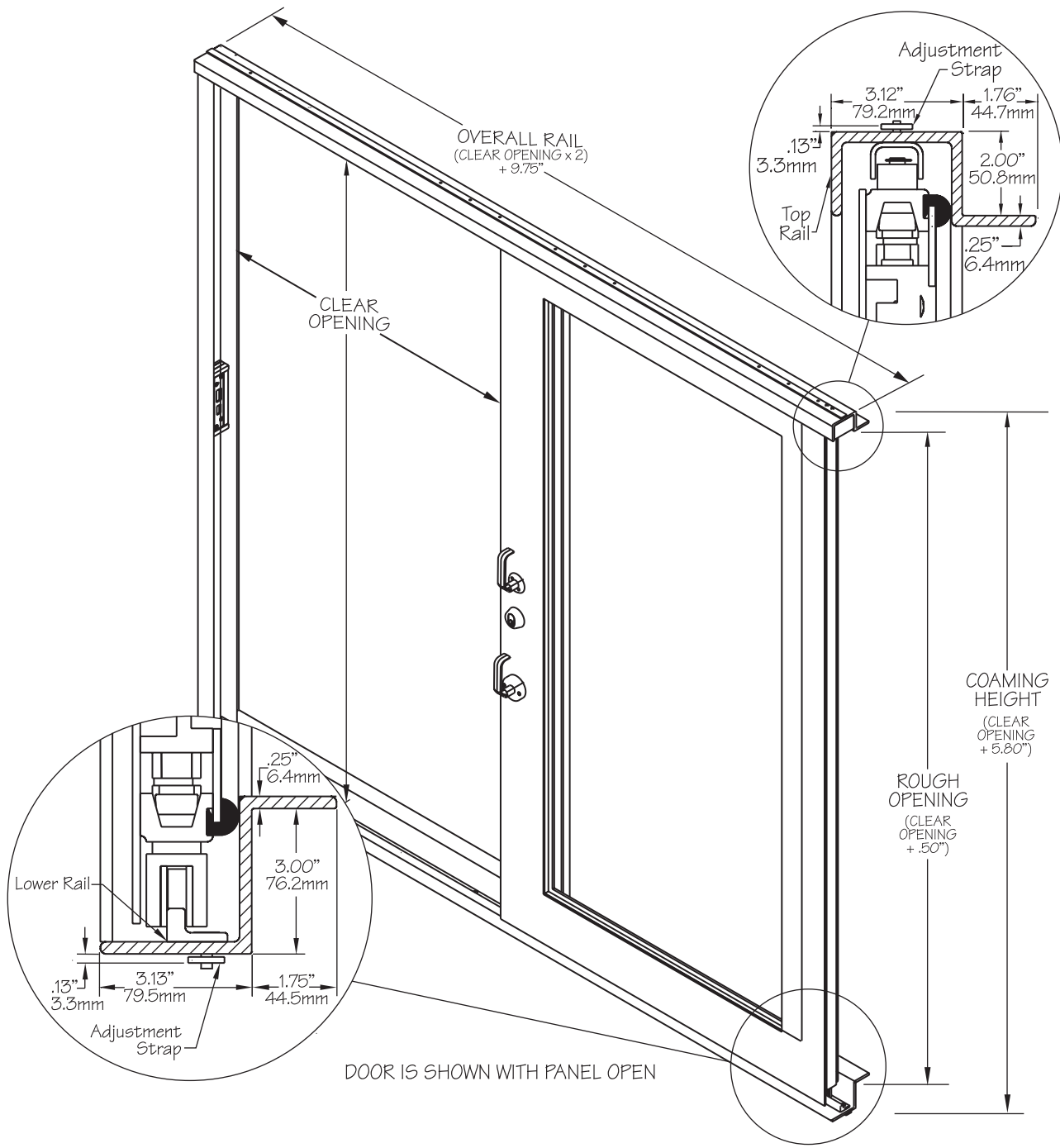

Scale None

© ALL RIGHTS RESERVED
2003 FREEMAN MARINE EQUIPMENT, INC.
SPECIFICATIONS SUBJECT TO CHANGE WITHOUT NOTICE

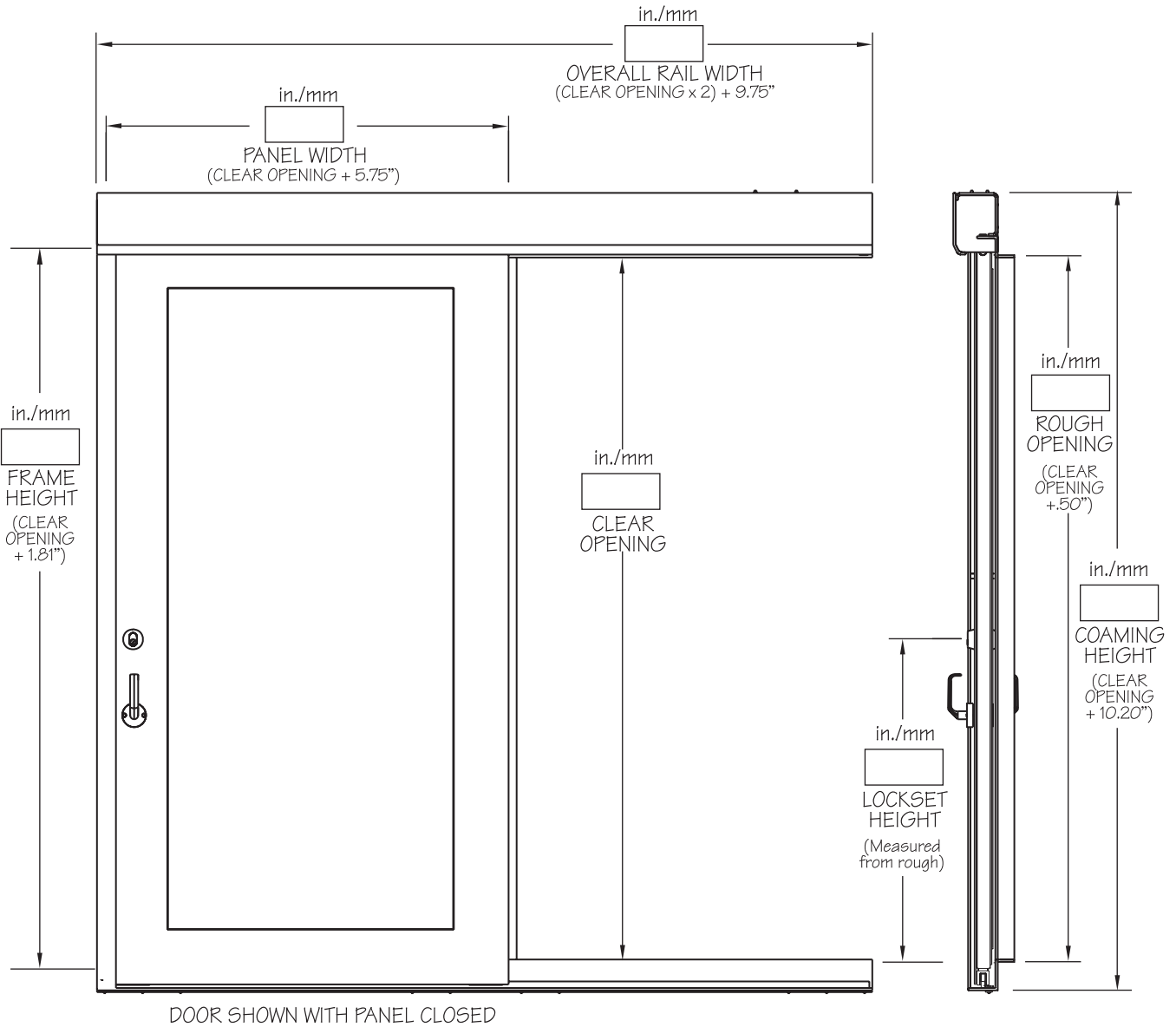

**LAYOUT
MODEL 1720**

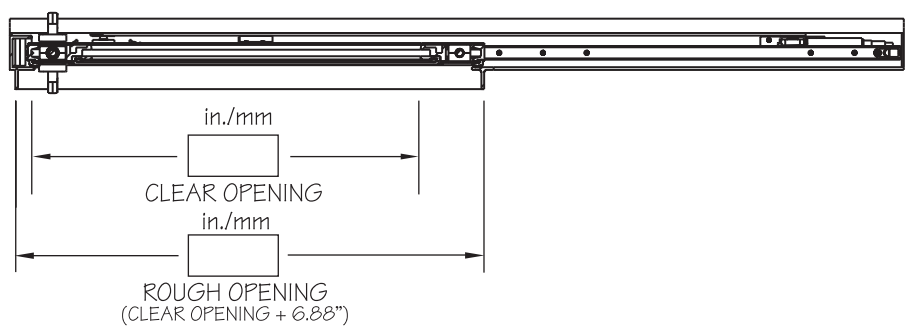

Scale	None
--------------	------

© ALL RIGHTS RESERVED
2003 FREEMAN MARINE EQUIPMENT, INC.
SPECIFICATIONS SUBJECT TO CHANGE WITHOUT NOTICE

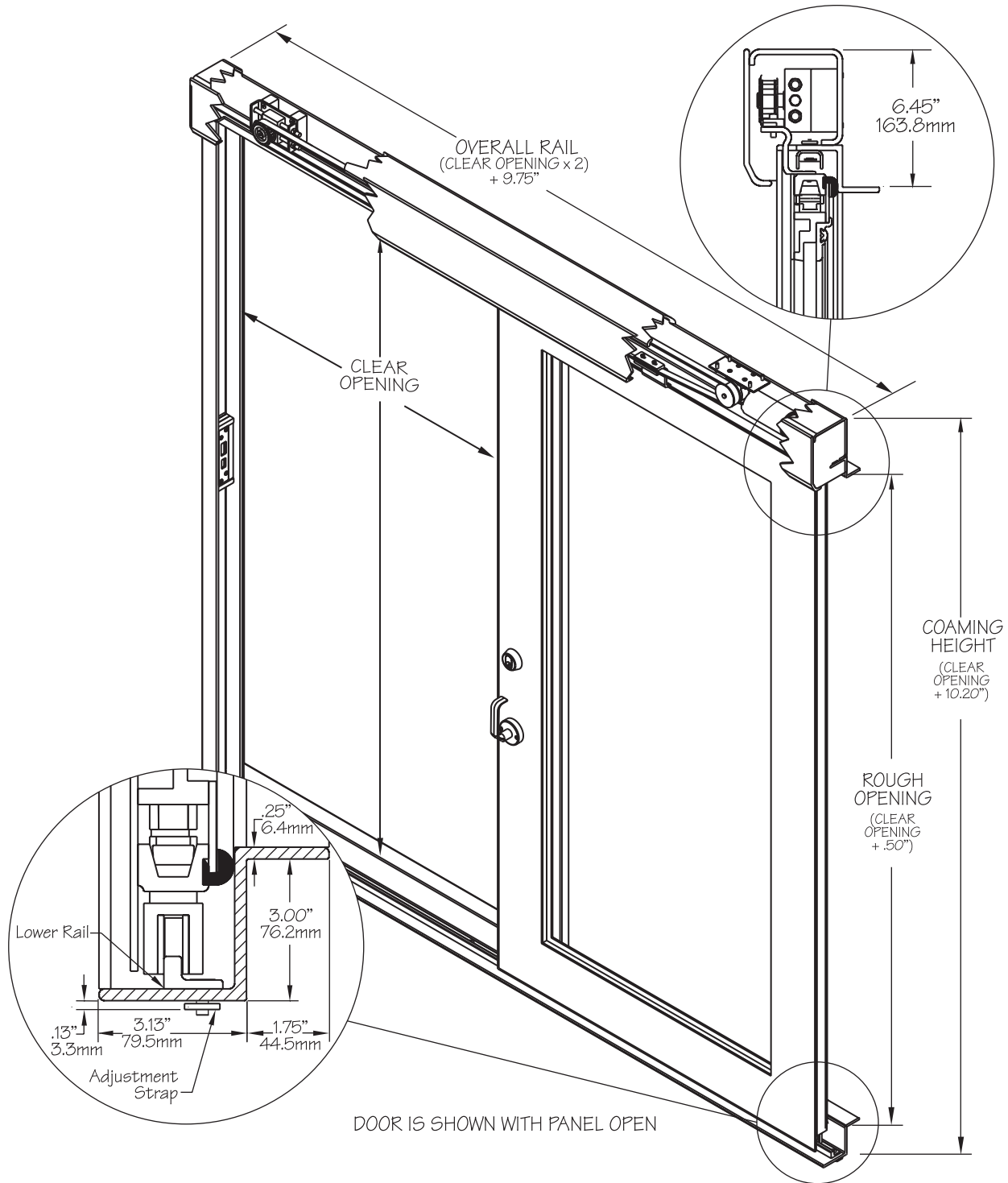

LAYOUT
MODEL 1720

Scale	None
--------------	------

© ALL RIGHTS RESERVED
2003 FREEMAN MARINE EQUIPMENT, INC.
SPECIFICATIONS SUBJECT TO CHANGE WITHOUT NOTICE

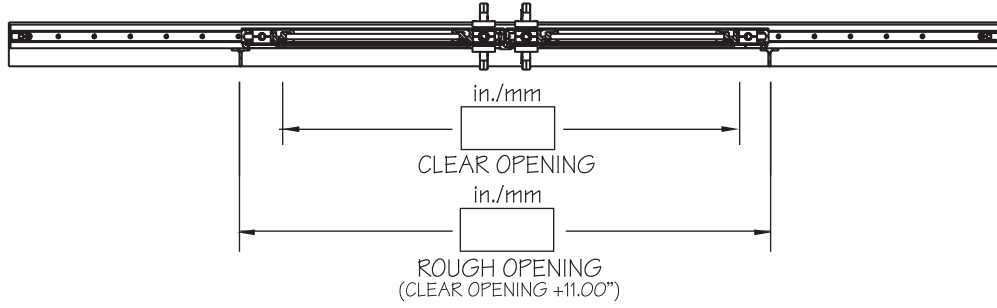
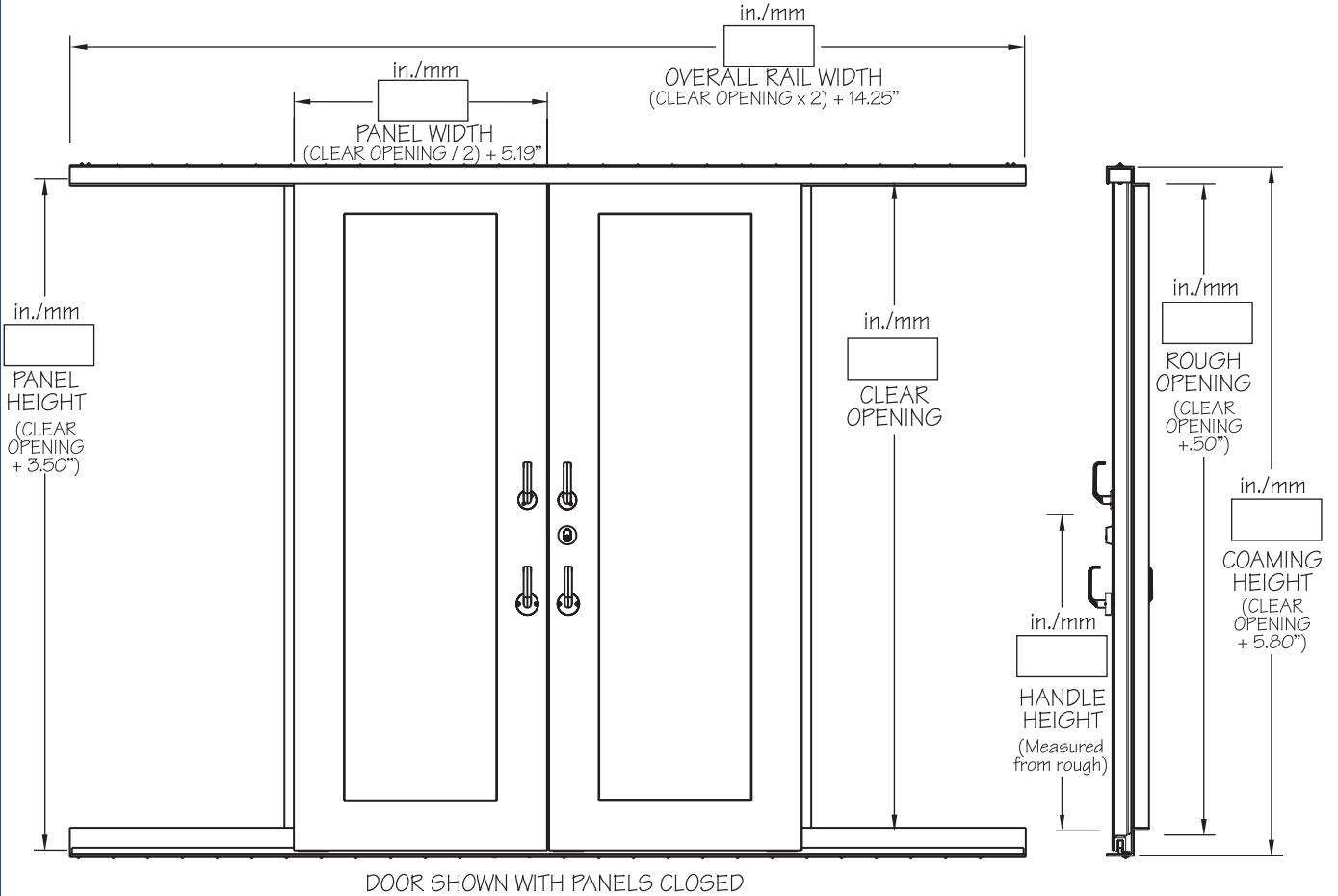

**LAYOUT
MODEL 1726**

Scale	None
--------------	------

© ALL RIGHTS RESERVED
2003 FREEMAN MARINE EQUIPMENT, INC.
SPECIFICATIONS SUBJECT TO CHANGE WITHOUT NOTICE

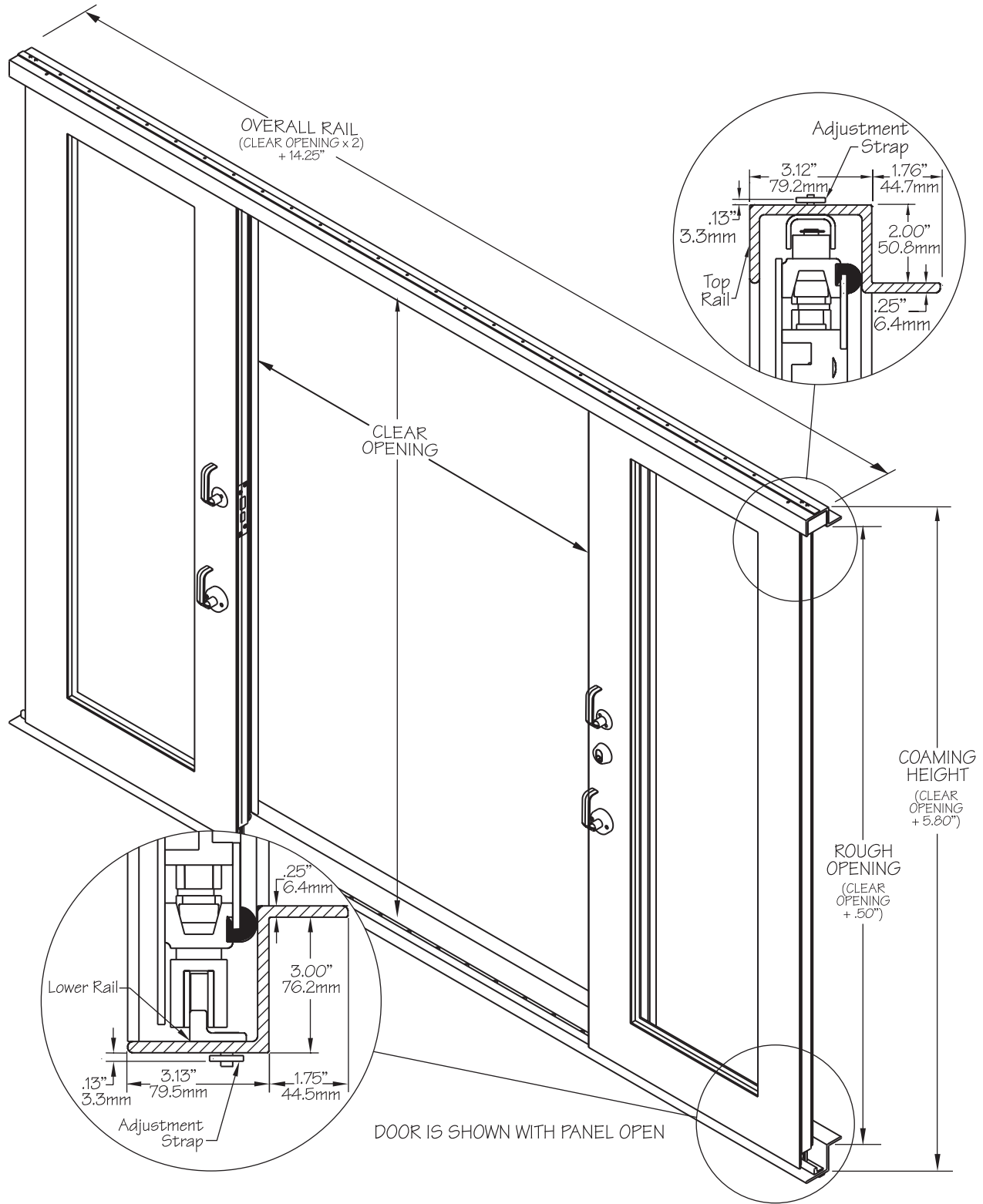

**LAYOUT
MODEL 1726**

Scale	None
--------------	------

© ALL RIGHTS RESERVED
2003 FREEMAN MARINE EQUIPMENT, INC.
SPECIFICATIONS SUBJECT TO CHANGE WITHOUT NOTICE

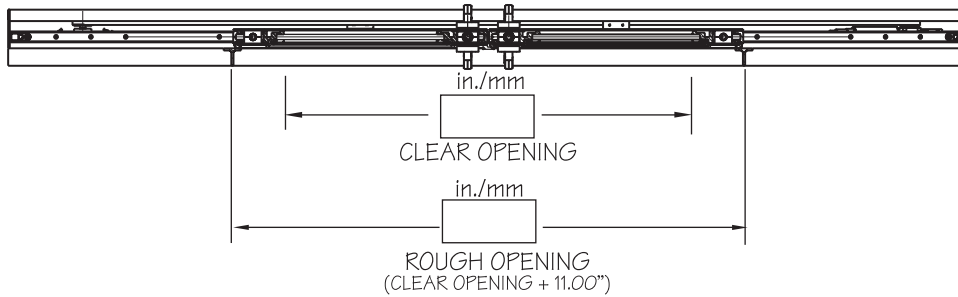
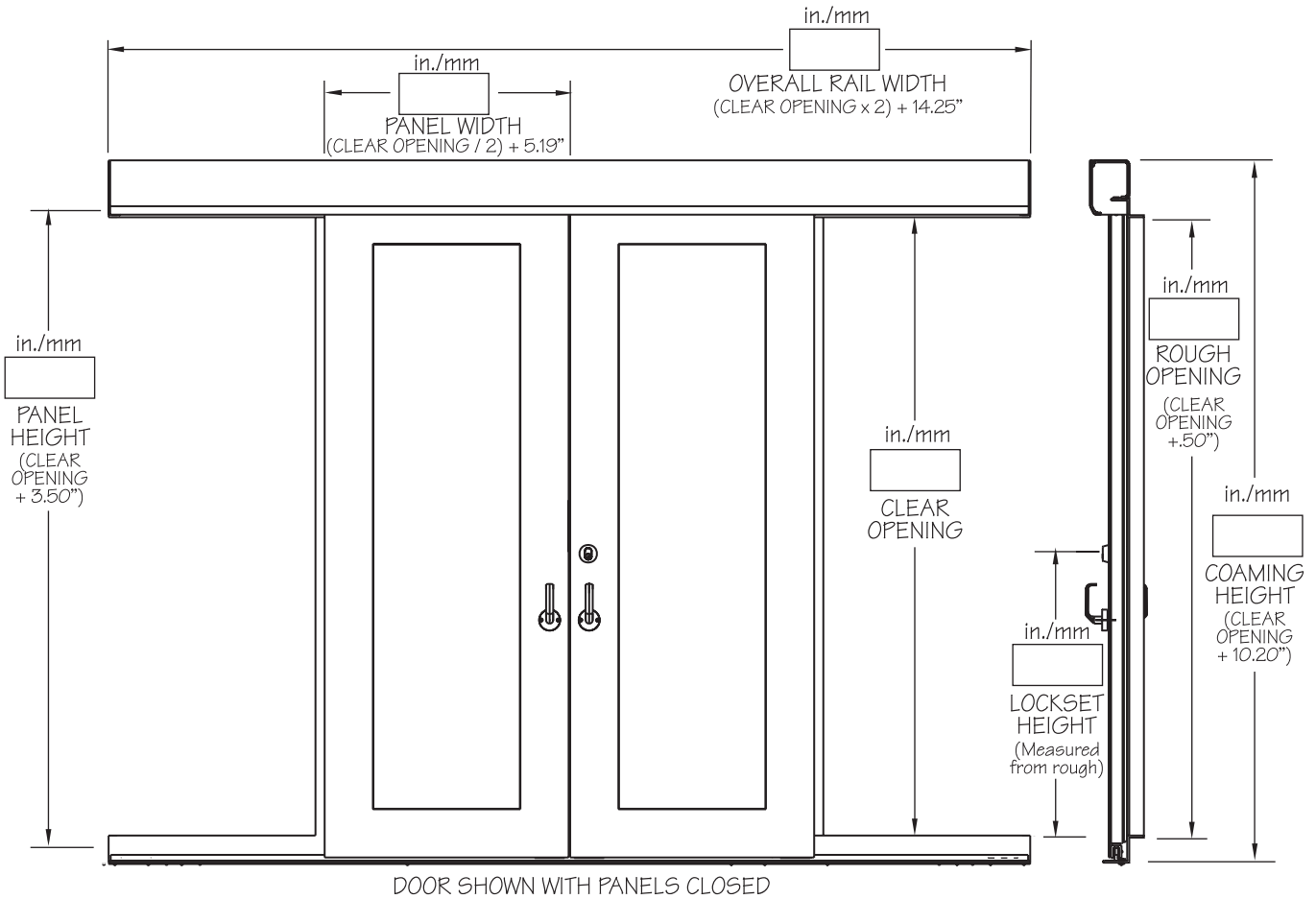

**LAYOUT
MODEL 1726**

Scale	None
--------------	------

© ALL RIGHTS RESERVED
2003 FREEMAN MARINE EQUIPMENT, INC.
SPECIFICATIONS SUBJECT TO CHANGE WITHOUT NOTICE

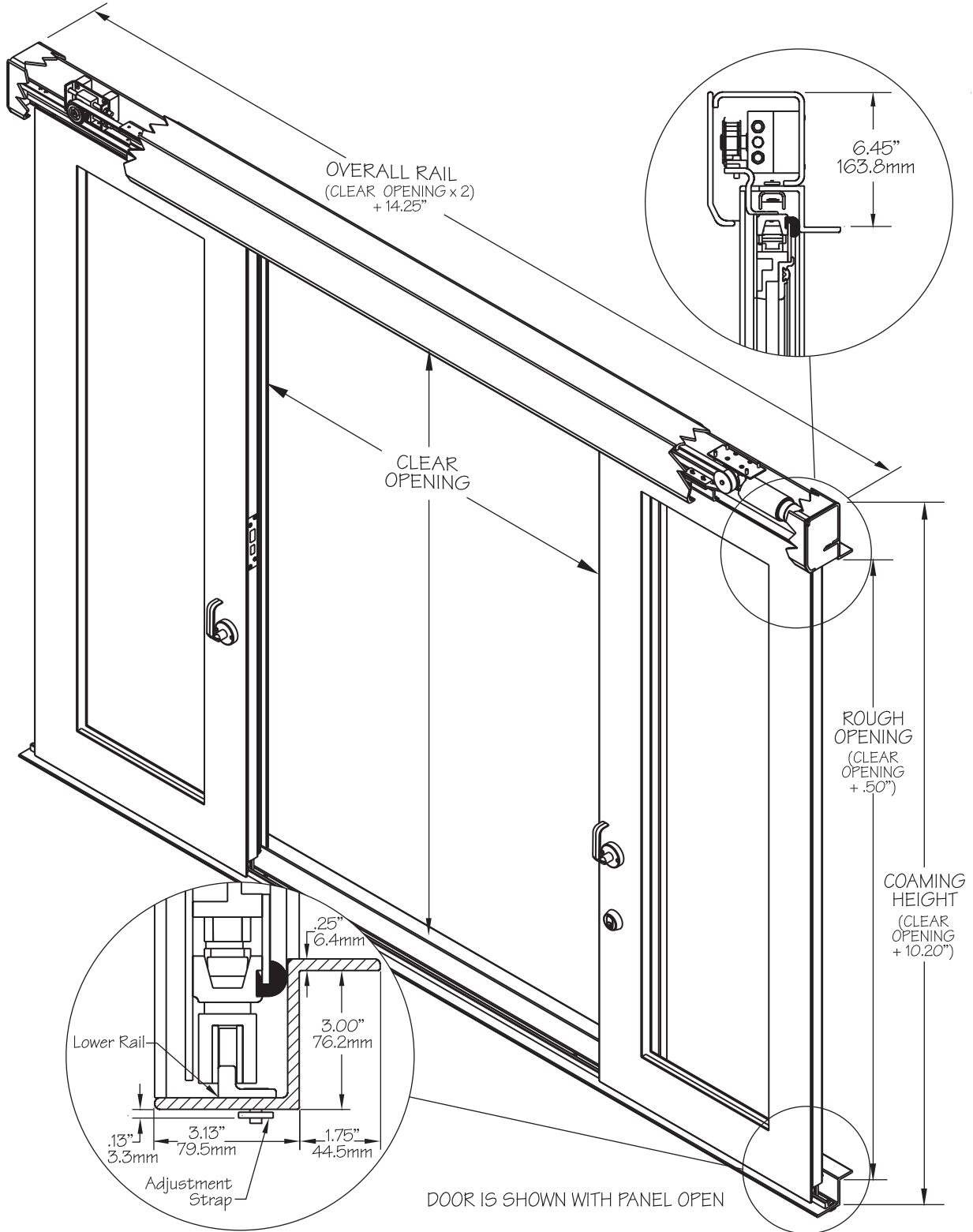

LAYOUT
MODEL 1726

Scale None

© ALL RIGHTS RESERVED
2003 FREEMAN MARINE EQUIPMENT, INC.
SPECIFICATIONS SUBJECT TO CHANGE WITHOUT NOTICE