

FREEMAN MARINE'S Single-Axis sliding doors offer traditional felted strip weather tight sealing. Sliding doors can be specified in virtually any size required and a variety of configurations; single panel, bi-parting, and multi-panel styles. Custom sized windows designed to complement adjacent vessel windows can be ordered. Passive solid panels as well as sidelights are also available.

FREEMAN Sliding doors are finished in yacht-quality linear polyurethane and offer attention to detail, durability, performance and style not found in lighter duty, ordinary sliding doors. Typical installations:

- Pilothouse • Galley • Salon Entry



Most sliders are fully finish-painted and provided with windows and hardware per customer's specification.



SINGLE-AXIS DESIGN FEATURES

- Felt Strip Weather Sealed
- Economical
- Versatile
- Precision Crafted Panels
 - Painted
 - Stainless Steel
- Noise-isolating Rollers
- Quality Latches and Hardware
- Custom Sized Windows
- Flat and Knuckle Panels
- Single, Bi-Parting and Multi-Panel Doors
- Automatic Operation (avail)



Full glass, Mitered corners



Full glass, Aft access, Closed



Pilothouse door, Upper window, Radius corners

Space required for automatic drive system



Interior detail, Lockset, Felt seal, Mullion



Felt seal, Lower track detail



Side entry, Open

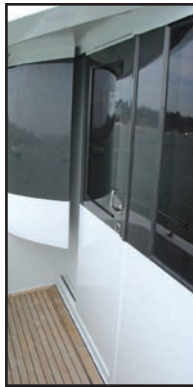

Side entry, Closed



Full glass, Radius corners



Interior view, Faux painted woodgrain

Center mullion, Sealing strip detail



Felt seal detail, Bottom track, Latch side



Felt seal detail, Latch plate



Custom shaped window, Automatic, Customer installed glass

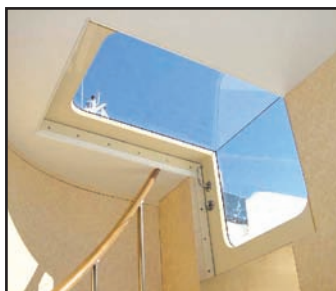

Knuckle flybridge, Radius glass, Interior view



Pilothouse door, Upper window, Radius corners



Bi-parting, Radius corner glass, Sidelights, Automatic

Hold open, Drop bolt



Lower track detail



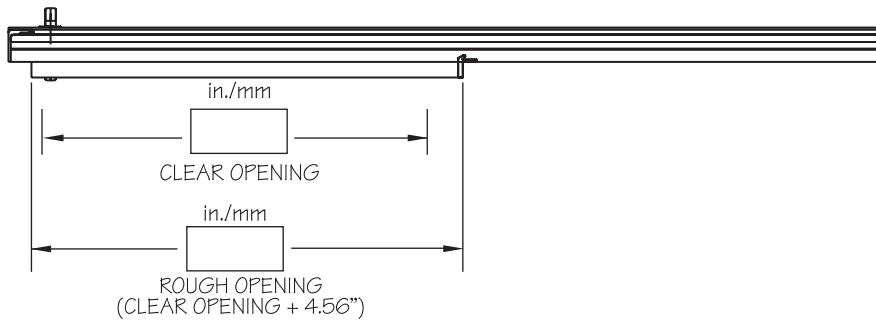
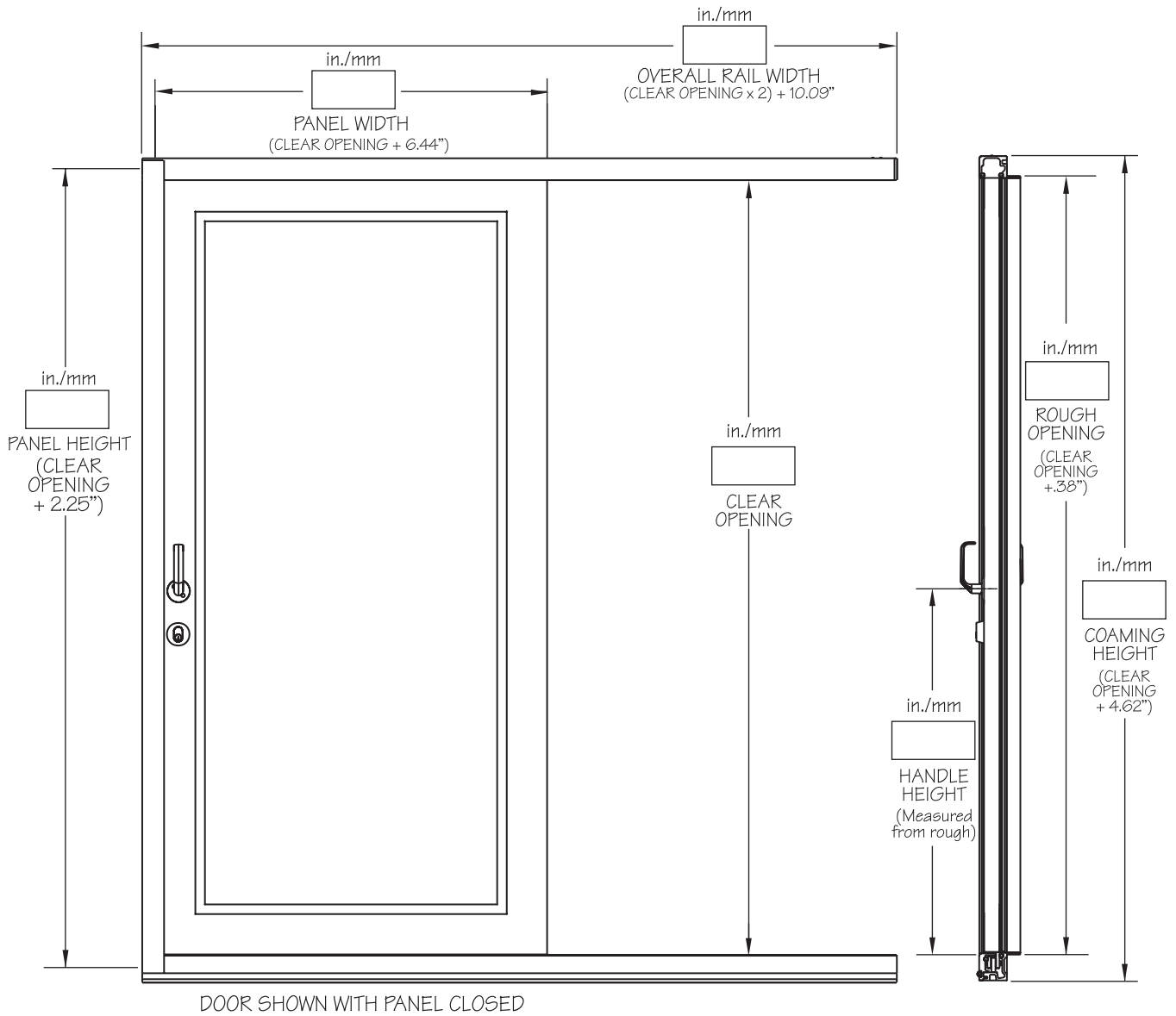

Scale None

© ALL RIGHTS RESERVED
 2003 FREEMAN MARINE EQUIPMENT, INC.
 SPECIFICATIONS SUBJECT TO CHANGE WITHOUT NOTICE

LAYOUT
 MODEL 1710

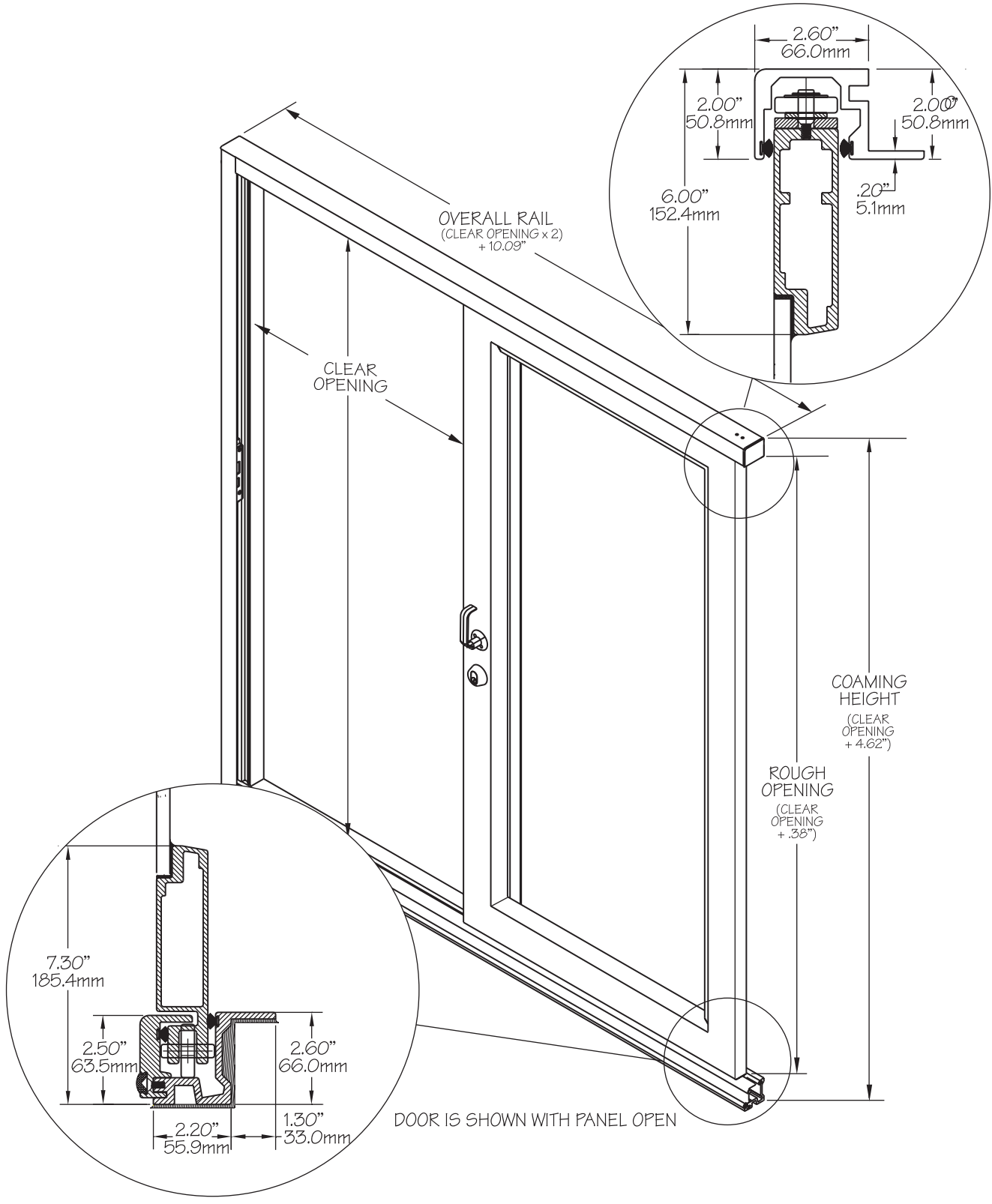

Scale	None
--------------	------

© ALL RIGHTS RESERVED
2003 FREEMAN MARINE EQUIPMENT, INC.
SPECIFICATIONS SUBJECT TO CHANGE WITHOUT NOTICE

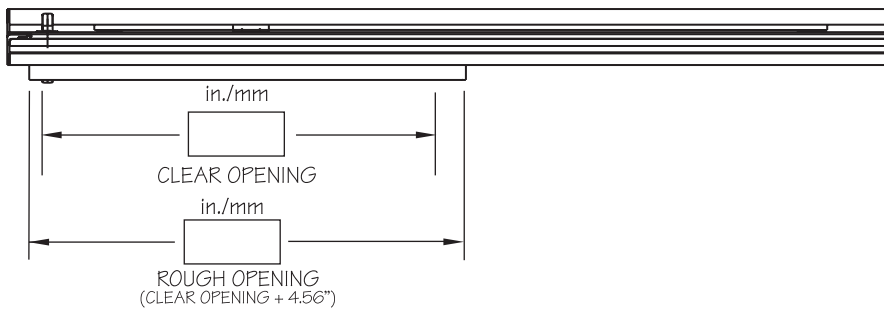
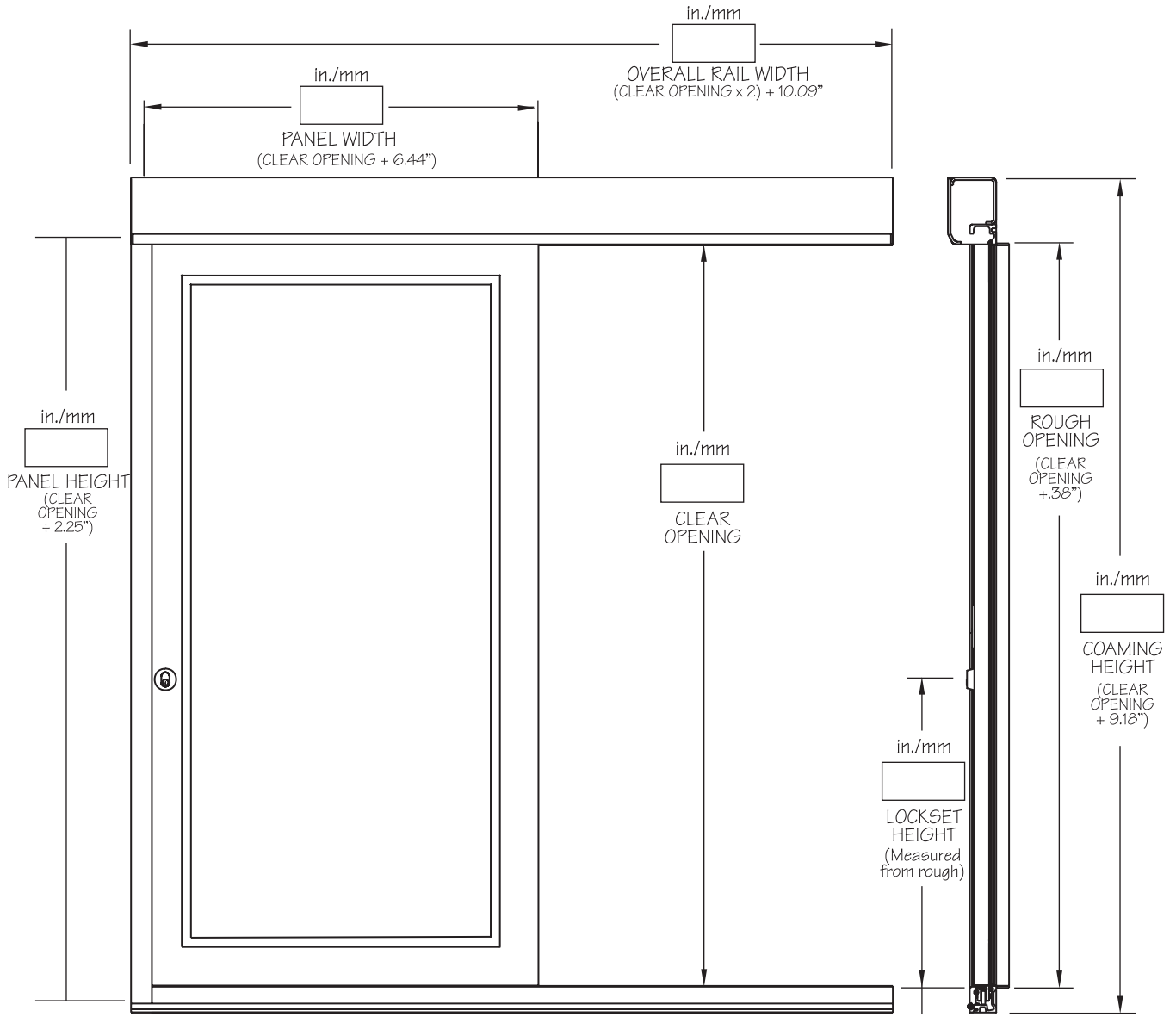

**LAYOUT
MODEL 1710**

Scale None

© ALL RIGHTS RESERVED
2003 FREEMAN MARINE EQUIPMENT, INC.
SPECIFICATIONS SUBJECT TO CHANGE WITHOUT NOTICE

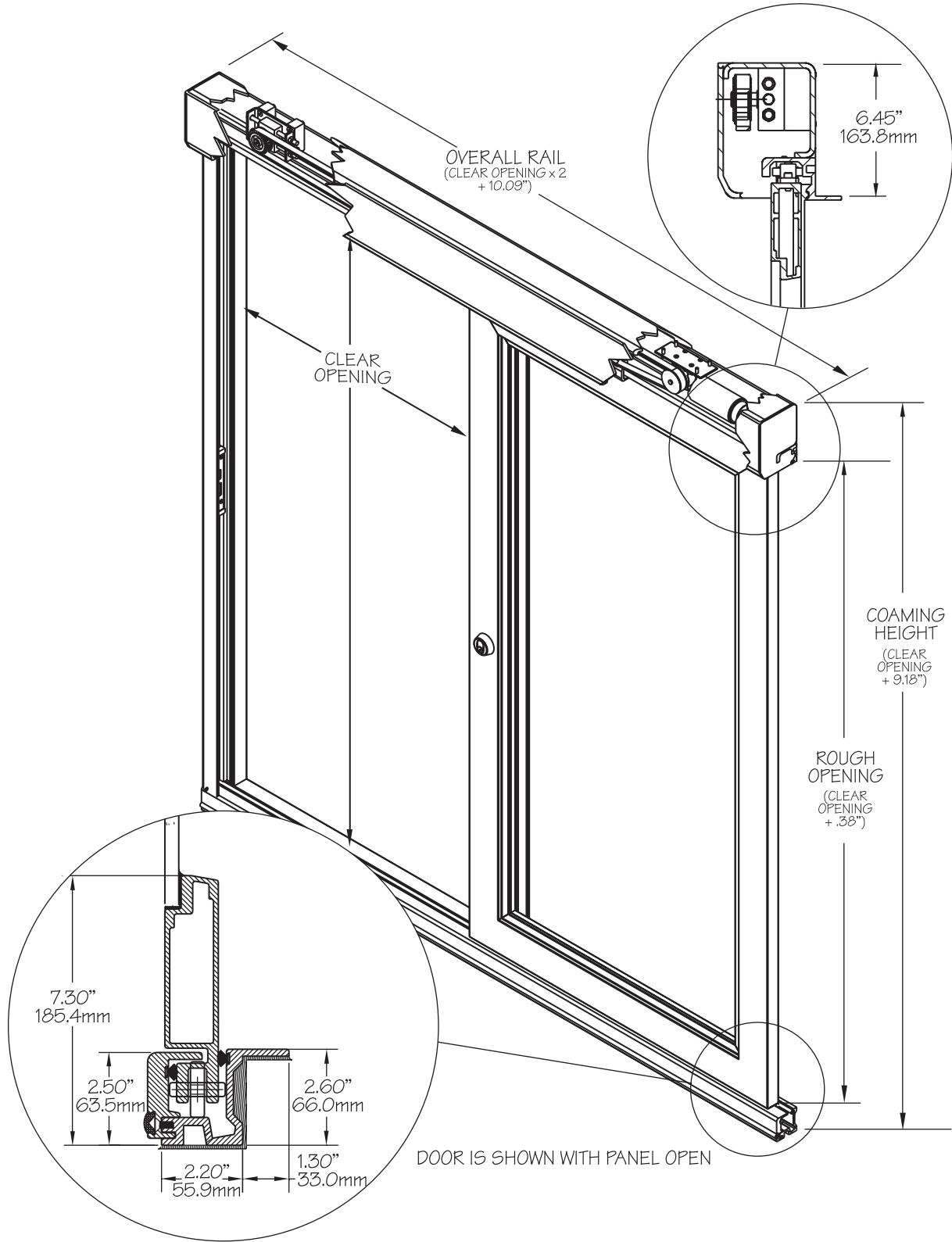

LAYOUT
MODEL 1710

Scale None

© ALL RIGHTS RESERVED
2003 FREEMAN MARINE EQUIPMENT, INC.
SPECIFICATIONS SUBJECT TO CHANGE WITHOUT NOTICE

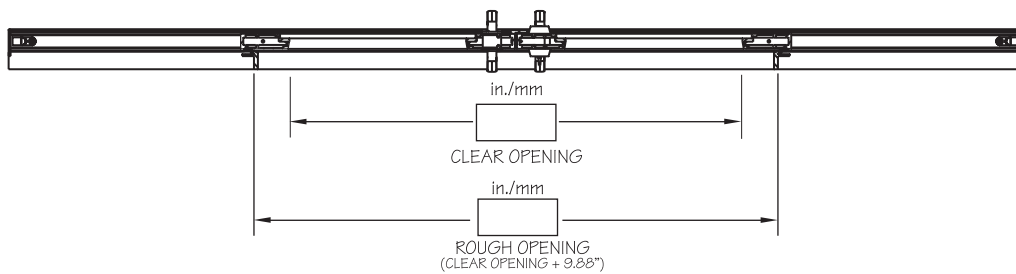
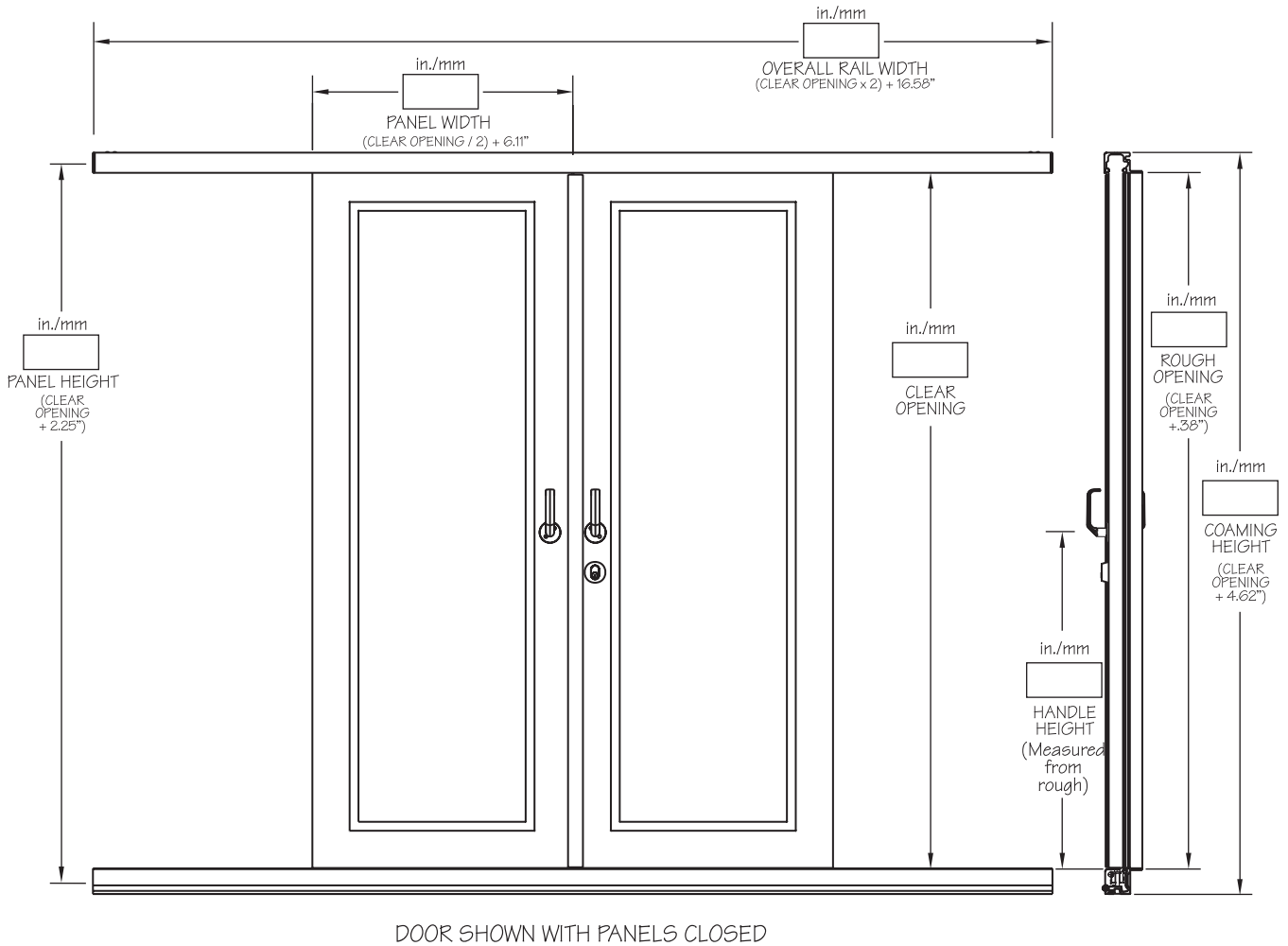

**LAYOUT
MODEL 1716**

Scale	None
--------------	------

© ALL RIGHTS RESERVED
2003 FREEMAN MARINE EQUIPMENT, INC.
SPECIFICATIONS SUBJECT TO CHANGE WITHOUT NOTICE

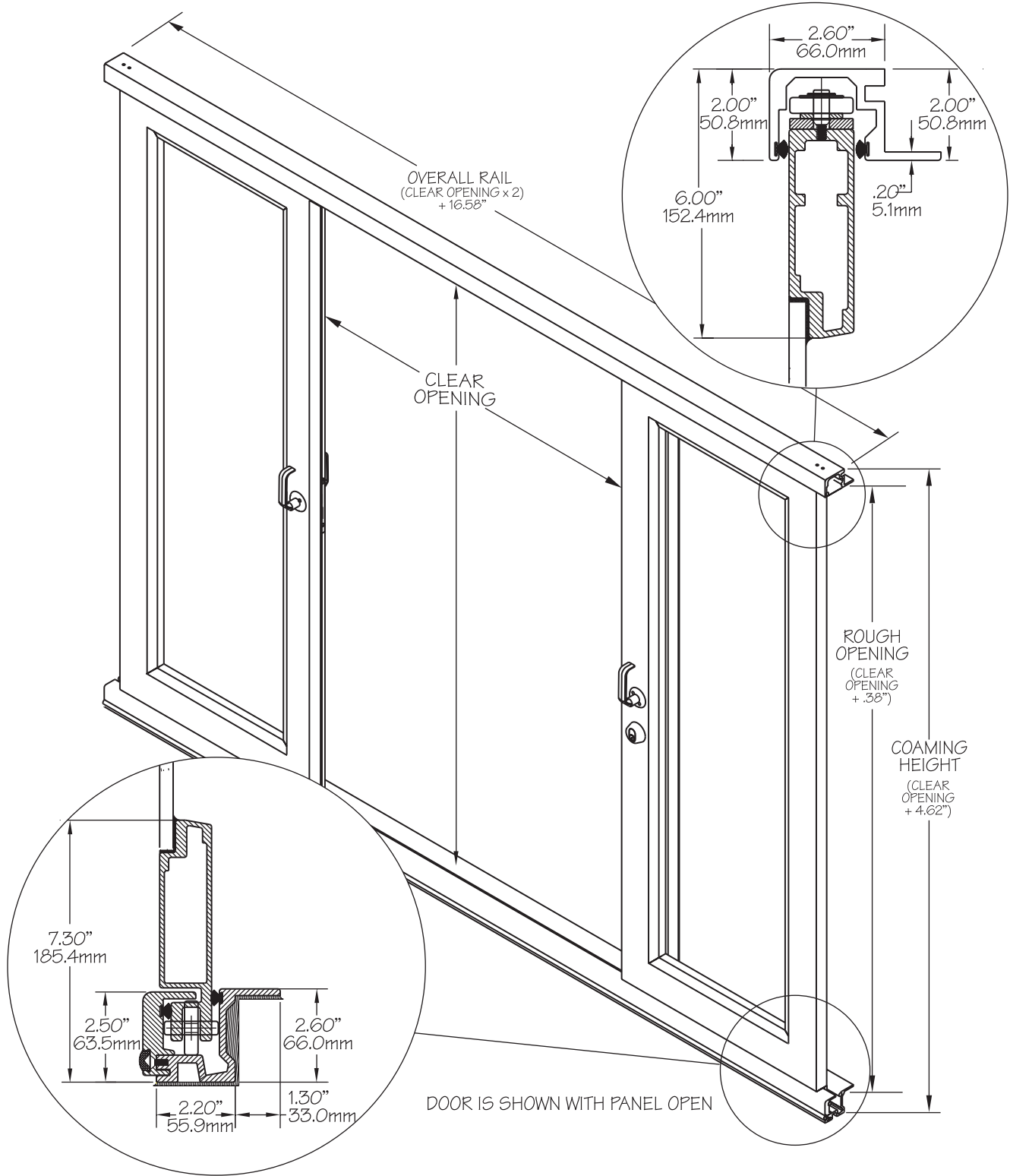

Scale None

© ALL RIGHTS RESERVED
2003 FREEMAN MARINE EQUIPMENT, INC.
SPECIFICATIONS SUBJECT TO CHANGE WITHOUT NOTICE

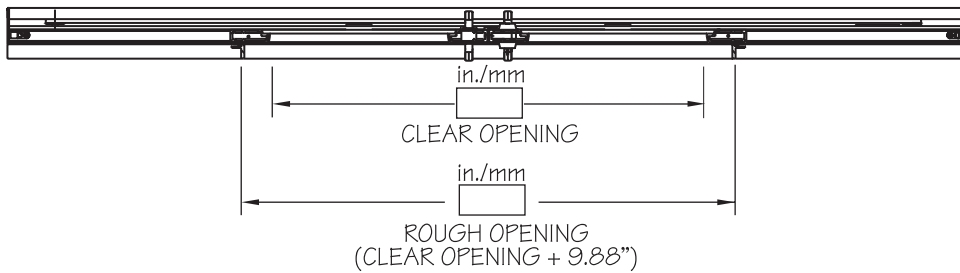
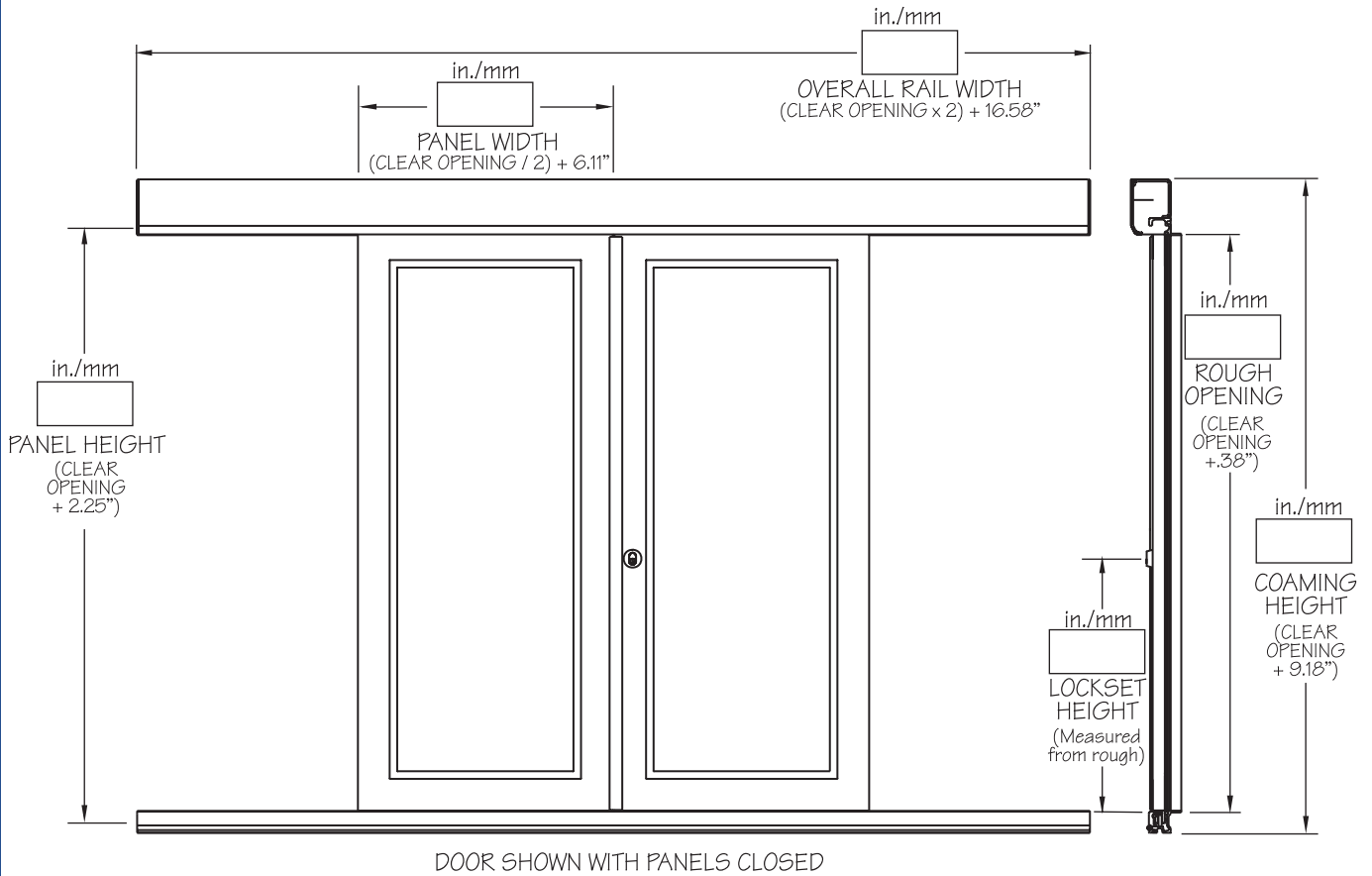

**LAYOUT
MODEL 1716**

Scale	None
--------------	------

© ALL RIGHTS RESERVED
2003 FREEMAN MARINE EQUIPMENT, INC.
SPECIFICATIONS SUBJECT TO CHANGE WITHOUT NOTICE

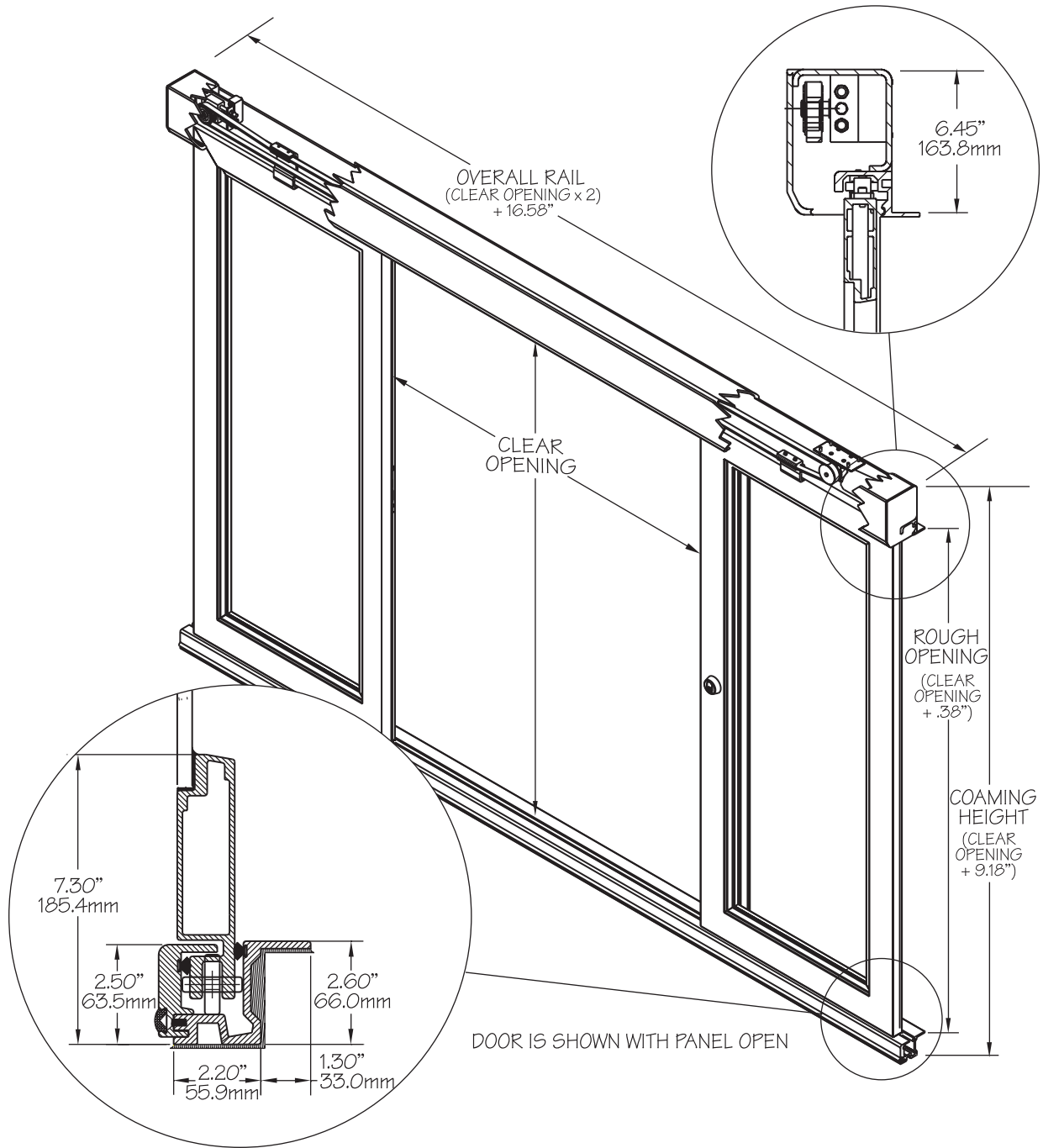

LAYOUT
MODEL 1716

Scale	None
--------------	------

© ALL RIGHTS RESERVED
2003 FREEMAN MARINE EQUIPMENT, INC.
SPECIFICATIONS SUBJECT TO CHANGE WITHOUT NOTICE